

ZOOM

NOVITÀ - UTENSILI DA TAGLIO

GIUGNO 2017 - LUGLIO 2017

25 ANNI DI CDU - *Celebriamo con voi il nostro 25° anniversario*

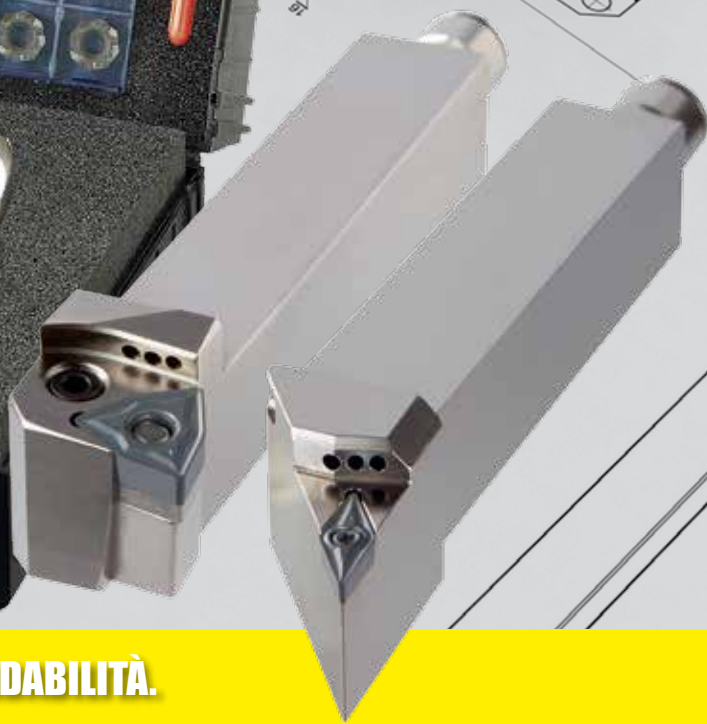
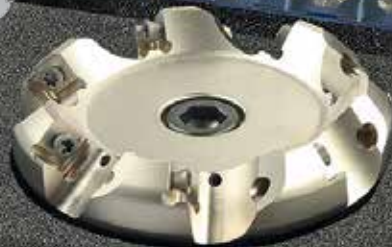

SPECIALE:

TKn

GARANZIA DI INNOVAZIONE, TECNOLOGIA E AFFIDABILITÀ.



**CONSORZIO
DISTRIBUTORI
UTENSILI**



www.cdu.net



FRESA AD INSERTI PER SPIANATURA A 45° CON ATTACCO A MANICOTTO



Fresa ad inserti per spianatura a 45° a passo differenziato, con passaggio interno del lubrorefrigerante, dalla geometria negativa utilizzabile su macchine con potenze medio alte.

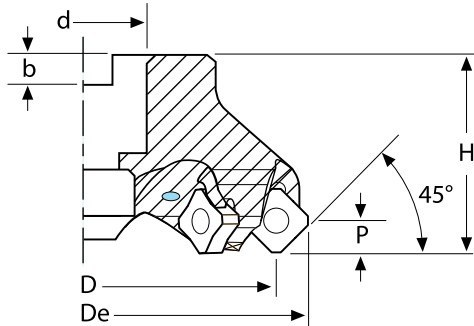

-25%
25 ANNI DI CDU



A58013	€	ZOOM special price	Dimensioni						
			D (mm)	De (mm)	d (H7) (mm)	H (mm)	p (mm)	Z	
0050	125,80	94,35	50	63	22	40	6	4	
0063	148,15	111,15	63	76	22	40	6	6	
0080	175,70	131,80	80	93	27	50	6	7	

Ricambi		
Inserto	Vite	Giravite
 SNEX SNKX SNMX 1206 SNMU 1260 ONMU 1205	 A91 035 0045	 A55 925 0100

ASSORTIMENTO FRESA AD INSERTI PER SPIANATURA A 45° CON ATTACCO A MANICOTTO



Assortimento fresa ad inserti per spianatura a 45° con attacco a manicotto, con passaggio interno del lubrorefrigerante, con la possibilità di montare due tipologie di inserti tipo SNMU e ONMU.



NEW



-25%
25 ANNI DI CDU



INSERTO



Inserto in metallo duro ONMU.



NEW

-25%
25 ANNI DI CDU

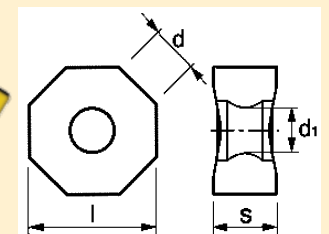

A93210	€	ZOOM special price	Pz	l (mm)	d (mm)	s (mm)	d1 (mm)	r (mm)	Rivestiti
0540	11,30	8,50	◆ 10	12,7	4,8	6	5,2	0,5	RP 200
0545	11,30	8,50	◆ 10	12,7	4,8	6	5,2	0,5	RP 300
0550	11,30	8,50	◆ 10	12,7	4,8	6	5,2	0,5	RK 300

A58013	€	ZOOM special price	Composto da							
9000	322,60	241,95	◆	1 fresa cod. A58 013 0050 + 10 inserti SNMU 1260 ANER cod. A93 205 1550 + 10 inserti ONMU 1205 ANN cod. A93 210 0550						
9005	340,05	255,05	◆	1 fresa cod. A58 013 0063 + 10 inserti SNMU 1260 ANER cod. A93 205 1550 + 10 inserti ONMU 1205 ANN cod. A93 210 0550						
9010	375,00	281,25	◆	1 fresa cod. A58 013 0080 + 10 inserti SNMU 1260 ANER cod. A93 205 1550 + 10 inserti ONMU 1205 ANN cod. A93 210 0550						



FRESA AD INSERTI PER SPALLAMENTI A 90° CON ATTACCO A MANICOTTO



Fresa ad inserti per spallamenti a 90° con attacco a manicotto, **con passaggio interno del lubrorefrigerante**, il passo a incremento asimmetrico permette rotazioni più regolari con buone prestazioni di taglio. Consigliato l'utilizzo su macchine stabili nelle fresature dal pieno.

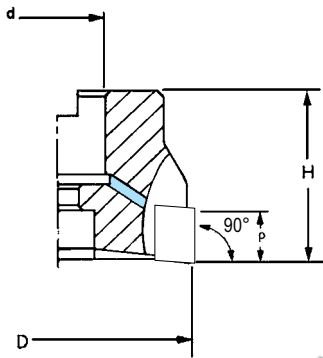

A58022	€	ZOOM special price		Dimensioni				
				D (mm)	d (mm)	H (mm)	P (mm)	Z
0032	172,65	129,50	◆	32	16	40	5,2	8
0040	194,50	145,90	◆	40	16	40	5,2	10
0050	210,15	157,65	◆	50	22	40	5,2	11

VITE



Ricambio vite.



A91035	€	ZOOM special price		Dimensione	N° Torx®
0105	7,70	5,80	◆	M1,8x4	6

Ricambi		
Inserto	Vite	Giravite
APKT 0602	A91 035 0105	A55 925 0060

FRESA AD INSERTI PER SPALLAMENTI A 90° CON CODOLO FILETTATO



Fresa ad inserti per spallamenti a 90° con codolo filettato, **con passaggio interno del lubrorefrigerante**, il passo a incremento asimmetrico permette rotazioni più regolari con buone prestazioni di taglio. Consigliato l'utilizzo su macchine stabili nelle fresature dal pieno. Versione modulare da montare su adattatori o mandrini con sede filettata.

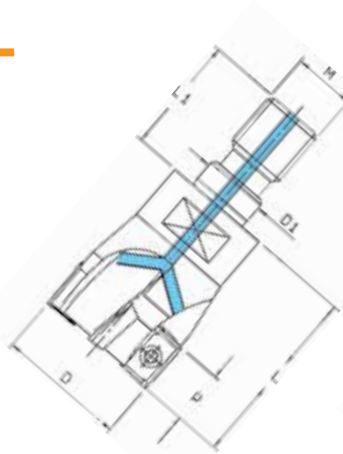

A58027	€	ZOOM special price		Dimensioni						
				D (mm)	D1 (mm)	L (mm)	L1 (mm)	M	p (mm)	Z
0010	95,90	71,95	◆	10	6,5	16	14,5	6	5,2	2
0012	123,85	92,90	◆	12	6,5	16	14,5	6	5,2	3
0016	148,25	111,20	◆	16	6,5	21	17,5	8	5,2	4
0020	160,50	120,40	◆	20	10,5	26	20	10	5,2	5
0025	172,70	129,55	◆	25	12,5	30	22	12	5,2	7

Ricambi		
Inserto	Vite	Giravite
APKT 0602	A91 035 0105	A55 925 0060



FRESA AD INSERTI PER SPALLAMENTI A 90°



Fresa ad inserti per spallamenti a 90° con attacco cilindrico e piano di trascinamento DIN 1835B, **con passaggio interno del lubrorefrigerante**, il passo a incremento asimmetrico permette rotazioni più regolari con buone prestazioni di taglio. Consigliato l'utilizzo su macchine stabili nelle fresature dal pieno con grandi profondità.

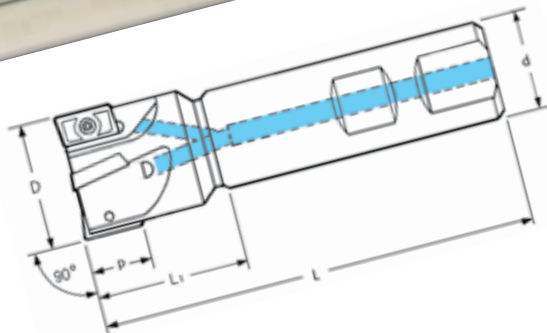
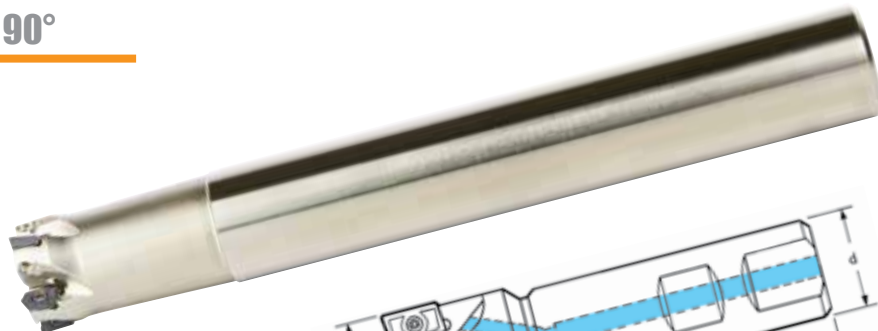

-25%
25 ANNI DI CDU



A58017	€	ZOOM special price	Dimensioni					Z
			D (mm)	d(h6) (mm)	L (mm)	L1 (mm)	p (mm)	
0010	74,15	55,65	10	10	100	28	5,2	2
0012	92,50	69,40	12	12	100	30	5,2	3
0014	92,50	69,40	14	12	120	32	5,2	3
0016	120,30	90,25	16	16	120	32	5,2	4
0018	120,30	90,25	18	16	120	32	5,2	4
0020	138,65	104,00	20	20	150	35	5,2	5
0025	154,30	115,75	25	20	150	35	5,2	7
0032	166,55	124,95	32	25	150	35	5,2	8

Ricambi		
Inserto	Vite	Giravite
APKT 0602	A91 035 0105	A55 925 0060

ASSORTIMENTO FRESA AD INSERTI PER SPALLAMENTI 90°



Assortimento fresa ad inserti per spallamenti 90° con attacco cilindrico e piano di trascinamento DIN 1835B, **con passaggio interno del lubrorefrigerante**, il passo a incremento asimmetrico permette rotazioni più regolari con buone prestazioni di taglio. Consigliato l'utilizzo su macchine stabili nelle fresature dal pieno con grandi profondità.



-25%
25 ANNI DI CDU



INSERTO

Inserto in metallo duro APKT PDTR-K.



-25%
25 ANNI DI CDU

A93015	€	ZOOM special price	Pz	l (mm)	d (mm)	s (mm)	d1 (mm)	r (mm)	Rivestiti
0255	6,35	4,80	10	6	3,66	2,16	2,06	0,4	RK400

A58017	€	ZOOM special price	Composto da						
9000	413,05	309,80	1 fresa cod. A58 017 0010 + 1 fresa cod. A58 017 0012 + 1 fresa cod. A58 017 0016 + 20 inserti APKT 060204 PDTR-K cod. A93 015 0255						



PORTAINSERTO PER TORNITURA ESTERNA 95° CON FORI PER LUBROREFRIGERANTE



Portainserto per tornitura esterna **con fori per l'adduzione interna del lubrorefrigerante** sul tagliente, fornito **con attacco rapido** posizionabile sul fondo o nella parte inferiore dello stelo, fissaggio a leva per inserto negativo a norma ISO, per lavorazioni di tornitura e sfacciatura.

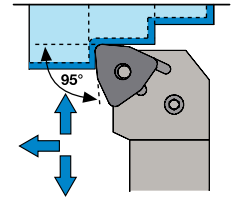
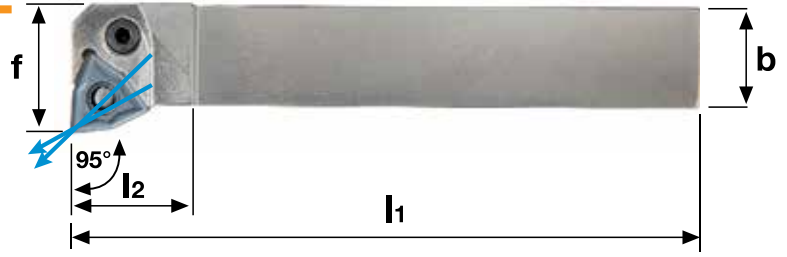

Ricambi					
Inserto	Sottopiacchetta	Leva	Vite	Spina	Punzone
WNMG 0804	A91 525 0005	A91 540 0005	A91 500 0005	A91 530 0005	A91 535 0005

-25%
25 ANNI DI CDU



A62207	€	ZOOM special price	ISO	Dimensioni					
				h1 (mm)	h2 (mm)	b (mm)	l1 (mm)	l2 (mm)	f (mm)
0120	163,90	122,95	◆ PVLNR 2020 K08 IK G1/8	20	20	20	125	25	25
0125	176,15	132,15	◆ PVLNR 2525 M08 IK G1/8	25	25	25	150	25	32
0220	163,90	122,95	◆ PVLNL 2020 K08 IK G1/8	20	20	20	125	25	25
0225	176,15	132,15	◆ PVLNL 2525 M08 IK G1/8	25	25	25	150	25	32

PORTAINSERTO PER TORNITURA ESTERNA 95° CON FORI PER LUBROREFRIGERANTE



Portainserto per tornitura esterna **con fori per l'adduzione interna del lubrorefrigerante** sul tagliente, fornito **con attacco rapido** posizionabile sul fondo o nella parte inferiore dello stelo, sede per l'inserto positivo a norma ISO con fissaggio a vite, da utilizzare nelle lavorazioni di tornitura e sfacciatura.

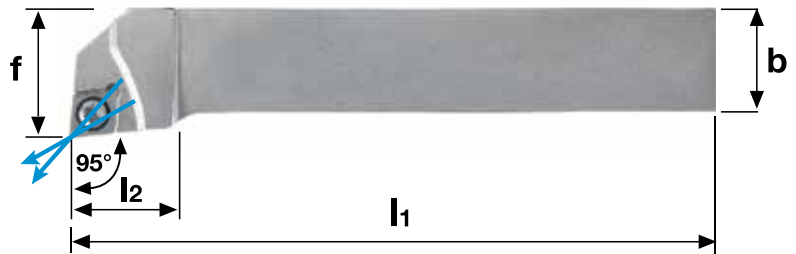
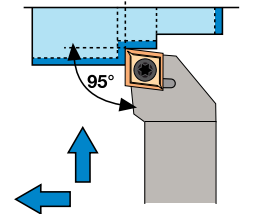

Ricambi				
Inserto	Sottopiacchetta	Vite	Vite	Giravite
CCMT-CCGT 09T3	A91 045 0005	A91 010 0005	A91 025 0005	A55 925 0090
CCMT-CCGT 1204	A91 045 0010	A91 010 0010	A91 025 0010	
CCMT-CCGT 09T3	A91 045 0005	A91 010 0005	A91 025 0005	
CCMT-CCGT 1204	A91 045 0010	A91 010 0010	A91 025 0010	

-25%
25 ANNI DI CDU



A62007	€	ZOOM special price	ISO	Dimensioni					
				h1 (mm)	h2 (mm)	b (mm)	l1 (mm)	l2 (mm)	f (mm)
0116	153,50	115,15	◆ SCLCR 1616 H09 IK G1/8	16	16	16	100	17	20
0120	158,70	119,05	◆ SCLCR 2020 K09 IK G1/8	20	20	20	125	17	25
0125	166,55	124,95	◆ SCLCR 2525 M12 IK G1/8	25	25	25	150	20	32
0216	153,50	115,15	◆ SCLCL 1616 H09 IK G1/8	16	16	16	100	17	20
0220	158,70	119,05	◆ SCLCL 2020 K09 IK G1/8	20	20	20	125	17	25
0225	166,55	124,95	◆ SCLCL 2525 M12 IK G1/8	25	25	25	150	20	32



PORTAINSERTI PER TORNITURA

PREZZI PROMOZIONALI VALIDI FINO AL 31.07.17

PORTAINSERTO PER TORNITURA ESTERNA 93° CON FORI PER LUBROREFRIGERANTE



Portainsero per tornitura esterna **con fori per l'adduzione interna del lubrorefrigerante** sul tagliente, fornito **con attacco rapido** posizionabile sul fondo o nella parte inferiore dello stelo, sede per l'inserto positivo a norma ISO con fissaggio a vite, da utilizzare nelle lavorazioni di tornitura e sfacciatura e copiatura.

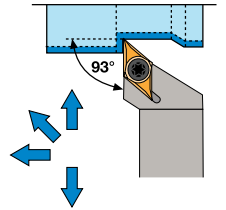
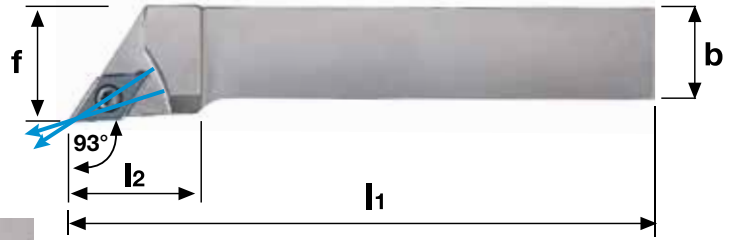

A62017	€	ZOOM special price	ISO	Dimensioni					
				h1 (mm)	h2 (mm)	b (mm)	l1 (mm)	l2 (mm)	f (mm)
0116	153,50	115,15	◆ SDJCR 1616 H11 IK G1/8	16	16	16	100	20	20
0120	158,70	119,05	◆ SDJCR 2020 K11 IK G1/8	20	20	20	125	20,5	25
0125	166,55	124,95	◆ SDJCR 2525 M11 IK G1/8	25	25	25	150	21,5	32
0216	153,50	115,15	◆ SDJCL 1616 H11 IK G1/8	16	16	16	100	20	20
0220	158,70	119,05	◆ SDJCL 2020 K11 IK G1/8	20	20	20	125	20,5	25
0225	166,55	124,95	◆ SDJCL 2525 M11 IK G1/8	25	25	25	150	21,5	32

Ricambi				
Inserto	Sottopiacchetta	Vite	Vite	Giravite
DCMT-DCGT 11T3	A91 050 0005	A91 010 0005	A91 025 0005	A55 925 0090

PORTAINSERTO PER TORNITURA ESTERNA 93° CON FORI PER LUBROREFRIGERANTE



Portainsero per tornitura esterna **con fori per l'adduzione interna del lubrorefrigerante** sul tagliente, fornito **con attacco rapido** posizionabile sul fondo o nella parte inferiore dello stelo, sede per l'inserto positivo a norma ISO con fissaggio a vite, da utilizzare nelle lavorazioni di tornitura e copiatura.

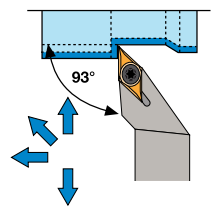
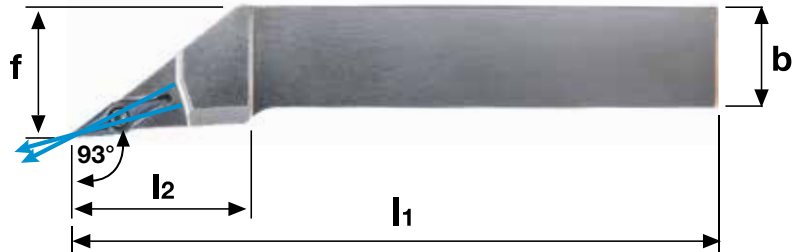

A62031	€	ZOOM special price	ISO	Dimensioni					
				h1 (mm)	h2 (mm)	b (mm)	l1 (mm)	l2 (mm)	f (mm)
0116	153,50	115,15	◆ SVJCR 1616 H11 IK G1/8	16	16	16	100	21,5	20
0120	158,70	119,05	◆ SVJCR 2020 K11 IK G1/8	20	20	20	125	23	25
0122	158,70	119,05	◆ SVJCR 2020 K16 IK G1/8	20	20	20	125	29,5	25
0125	166,55	124,95	◆ SVJCR 2525 M16 IK G1/8	25	25	25	150	32,5	32
0216	153,50	115,15	◆ SVJCL 1616 H11 IK G1/8	16	16	16	100	21,5	20
0220	158,70	119,05	◆ SVJCL 2020 K11 IK G1/8	20	20	20	125	23	25
0222	158,70	119,05	◆ SVJCL 2020 K16 IK G1/8	20	20	20	125	29,5	25
0225	166,55	124,95	◆ SVJCL 2525 M16 IK G1/8	25	25	25	150	32,5	32

Ricambi				
Inserto	Sottopiacchetta	Vite	Vite	Giravite
VCGT 1103	-	-	A91 025 0015	A55 925 0070
VCMT-VCGT 1604	A91 050 0010	A91 010 0005	A91 025 0005	A55 925 0090
VCGT 1103	-	-	A91 025 0015	A55 925 0070
VCMT-VCGT 1604	A91 050 0010	A91 010 0005	A91 025 0005	A55 925 0090



PORTAINSERTI PER TORNITURA

PREZZI PROMOZIONALI VALIDI FINO AL 31.07.17

PORTAINSERTO PER TORNITURA ESTERNA 95° CON FORI PER LUBROREFRIGERANTE



Portainsero per tornitura esterna **con fori per l'adduzione interna del lubrorefrigerante** sul tagliente, fornito **con attacco rapido** posizionabile sul fondo o nella parte inferiore dello stelo, fissaggio a leva per inserto negativo a norma ISO, per lavorazioni di tornitura e sfacciatura.

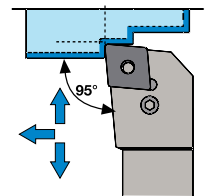
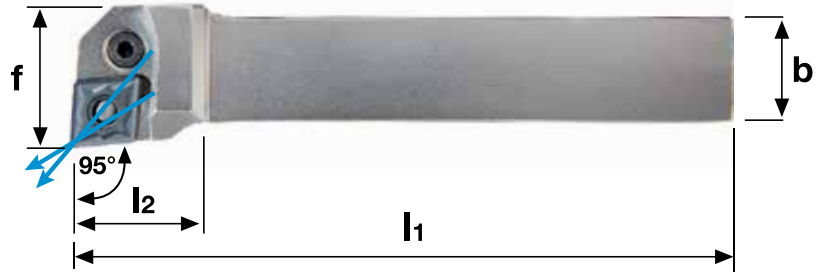

-25%
25 ANNI DI CDU

A62177	€	ZOOM special price	ISO	Dimensioni					
				h1 (mm)	h2 (mm)	b (mm)	l1 (mm)	l2 (mm)	f (mm)
0116	156,10	117,10	◆ PCLNR 1616 H12 IK G1/8	16	16	16	100	26,1	20
0120	163,90	122,95	◆ PCLNR 2020 K12 IK G1/8	20	20	20	125	27,4	25
0125	176,15	132,15	◆ PCLNR 2525 M12 IK G1/8	25	25	25	150	28	32
0216	156,10	117,10	◆ PCLNL 1616 H12 IK G1/8	16	16	16	100	26,1	20
0220	163,90	122,95	◆ PCLNL 2020 K12 IK G1/8	20	20	20	125	27,4	25
0225	176,15	132,15	◆ PCLNL 2525 M12 IK G1/8	25	25	25	150	28	32

Ricambi					
Inserto	Sottopiacchetta	Leva	Vite	Spina	Punzone
CNMG 1204	A91 505 0005	A91 540 0005	A91 500 0005	A91 530 0005	A91 535 0005

PORTAINSERTO PER TORNITURA ESTERNA 93° CON FORI PER LUBROREFRIGERANTE



Portainsero per tornitura esterna **con fori per l'adduzione interna del lubrorefrigerante** sul tagliente, fornito **con attacco rapido** posizionabile sul fondo o nella parte inferiore dello stelo, fissaggio a leva per inserto negativo a norma ISO, per lavorazioni di tornitura e sfacciatura.

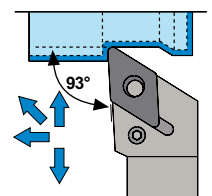
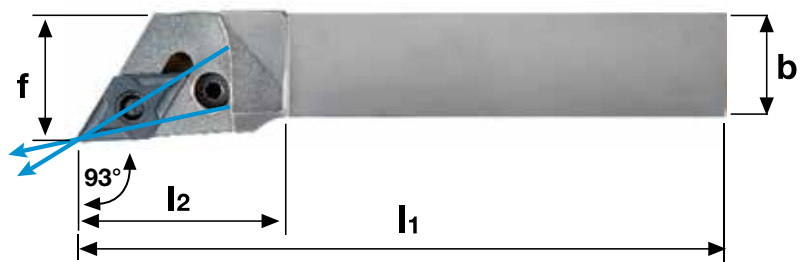

-25%
25 ANNI DI CDU

A62192	€	ZOOM special price	ISO	Dimensioni					
				h1 (mm)	h2 (mm)	b (mm)	l1 (mm)	l2 (mm)	f (mm)
0120	163,90	122,95	◆ PDJNR 2020 K15 IK G1/8	20	20	20	125	30	25
0125	176,15	132,15	◆ PDJNR 2525 M15 IK G1/8	25	25	25	150	30	32
0220	163,90	122,95	◆ PDJNL 2020 K15 IK G1/8	20	20	20	125	30	25
0225	176,15	132,15	◆ PDJNL 2525 M15 IK G1/8	25	25	25	150	30	32

Ricambi					
Inserto	Sottopiacchetta	Leva	Vite	Spina	Punzone
DNMG 1506	A91 510 0010	A91 540 0030	A91 500 0005	A91 530 0005	A91 535 0005



**la forza
di un gruppo**

CONSORZIATO

3 ERRE s.r.l.

Via dei Quadri, 62

BIERRE DI s.p.a.

Corso Perrone, 47/R

Via della Plastica, 6

Via delle Pianazze, 25

Via Valle Po, 145/B

Via Italia, 4

BINETTI s.r.l.

Via Papa Montini, 26

BRUNABOSI s.r.l.

Via Cerati, 1/A

Via Bruschi, 23 C-D-E

C.A.M.I. s.r.l.

Via Crevacuore, 27/A

Via Candelo, 67

DEGA & GRAZIOLI s.r.l.

Via Gian Battista Cacciamali, 52

F.LLI BONO s.p.a.

Via dell'Economia, 131

Via Lago di Lugano, 28

FERROJULIA s.r.l.

Via Grado, 48

G. REDAELLI s.p.a.

Via V. Emanuele, 34

GEMAR s.r.l.

Via Cancelliera, 71

GI.MA.T s.r.l.

Via Palma di Cesnola, 110

P. GROHE s.r.l.

Via Johann Georg Mahl, 11

LA MARCA s.r.l.

Via XI Settembre 2001, 26

MABRO s.r.l.

Via delle Fratte, 3/M

STOCCHI s.r.l.

Via Cavaliere di V. Veneto, 20

TECNOMECCANICA s.r.l.

Viale Don Minzoni, 3/N

TERRANOVA s.r.l.

Z.i., 3^a Strada, 46

Via VI Aprile, 73/75

Via Nazionale, 113

(ang. Via Torre)

Z.i. - Fase 1, viale 7, snc

TREVI s.r.l.

Via Roggia Vailata

CITTÀ

Bellusco (MB)

Genova

Alessandria

La Spezia

Madonna Dell'Olmo (CN)

Vado Ligure (SV)

Molfetta (BA)

Parma

Reggio Emilia

Serravalle Sesia (VC)

Biella

Brescia

Vicenza

Schio (VI)

Monfalcone (GO)

Besana B.Za (MB)

Ariccia (RM)

Torino

Brunico (BZ)

Mariglianella (NA)

S. Sisto (PG)

Bergamo

Jesi (AN)

Catania

Catania

Giammoro

Pace del Mela (ME)

Ragusa

Treviglio (BG)

TELEFONO

039/6021866

010/6592011

0131/249883

0187/982128

0171/413333

019/2160196

080/3384628

0521/984346

0522/302066

0163/450609

015/8493492

030/2680362

0444/990990

0445/575333

0481/719111

0362/995930

06/93021014

011/3173244

0474/547200

081/8411555

075/5289396

035/3693411

0731/207045

095/7357365

095/531019

090/9385359

0932/1882386

0363/343332



CONSORZIATO

UMAP s.r.l.

Via S. Penna, 19

U.M.C. s.p.a.

Via Porta, 2

UT. C. SPREAFICO s.r.l.

Via B. Buozi, 13/15

Via Liguria, 147

UT. LUGHESE s.r.l.

Via Piratello, 59/3

UT. MODENESE s.r.l.

Via Repubblica Val Taro, 220

UTEMAC s.r.l.

Via Armaroli, 1

UTENSILDODI s.r.l.

Via G. Boselli, 10

CITTÀ

Pistoia

Cassano Magnago (VA)

Lecco

Talamona (SO)

Lugo (RA)

Modena

Calderara Di Reno (BO)

Castel S. Giovanni (PC)

TELEFONO

0573/531212

0331/201057

0341/285675

0342/671277

0545/31905

059/452081

051/722436

0523/881747

Le promozioni sono valide dal 1 giugno 2017 al 31 luglio 2017 e/o fino ad esaurimento scorte. Sono disponibili esclusivamente presso i punti vendita delle utensilerie consorziate CDU.

CDU non risponde per eventuali errori tipografici o descrizioni errate di prodotti o caratteristiche tecniche. Le immagini hanno puro valore indicativo. I prezzi, ove indicati, si intendono al netto dell'IVA.



**CONSORZIO
DISTRIBUTORI
UTENSILI**



www.cdu.net