

# PROMO 2020

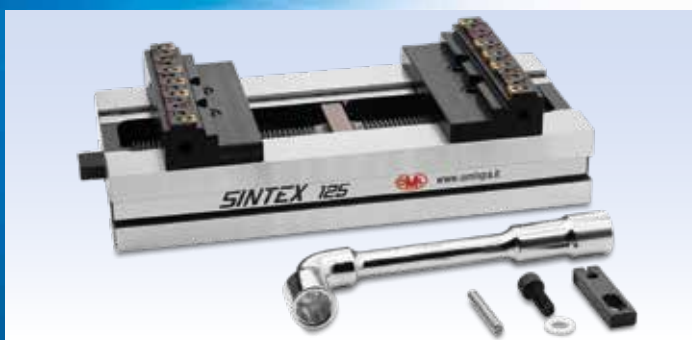

## MODULAR CLAMPING SYSTEMS



# SINTEX 100

PREMIUM



Completa di 10 inserti SinterGrip, 10 inserti di protezione, chiave, kit fermo laterale

Complete with 10 SinterGrip inserts, 10 protection inserts, wrench, workstop

Codice - Code	Descrizione - Description	Prezzo - Price (€)	Offerta - Offer (€)
77584911	SINTEX 100 STD	<del>1.268,00</del>	995,00
77584912	SINTEX 100 ALU	<del>1.268,00</del>	995,00
77584913	SINTEX 100 HRC	<del>1.268,00</del>	995,00

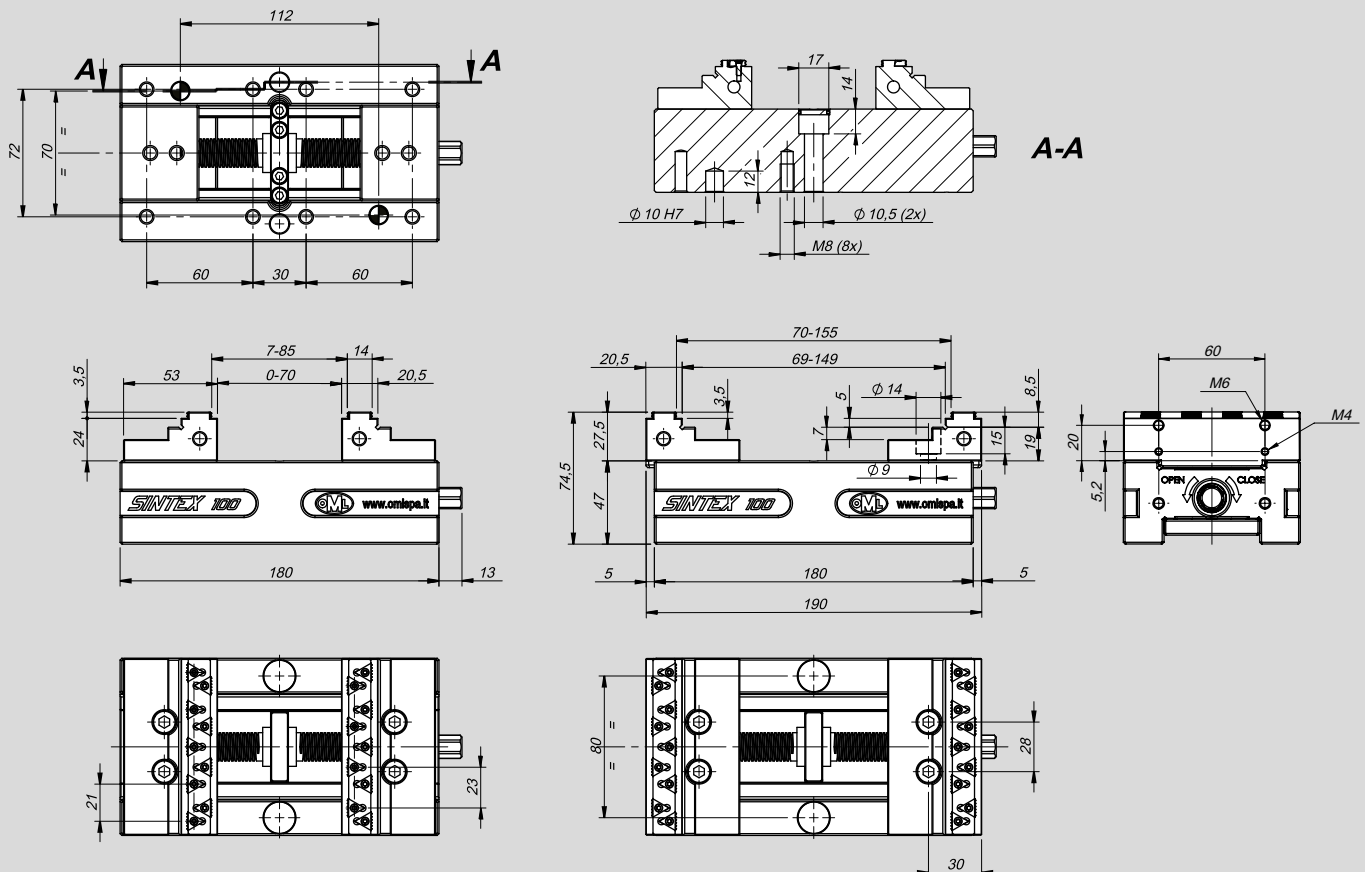

# SINTEX 125

PREMIUM

Completa di 10 inserti SinterGrip, 10 inserti di protezione, chiave, kit fermo laterale

Complete with 10 SinterGrip inserts, 10 protection inserts, wrench, workstop



Codice - Code	Descrizione - Description	Prezzo - Price (€)	Offerta - Offer (€)
77584961	SINTEX 125 STD	<del>1.731,00</del>	1.200,00
77584962	SINTEX 125 ALU	<del>1.731,00</del>	1.200,00
77584963	SINTEX 125 HRC	<del>1.731,00</del>	1.200,00

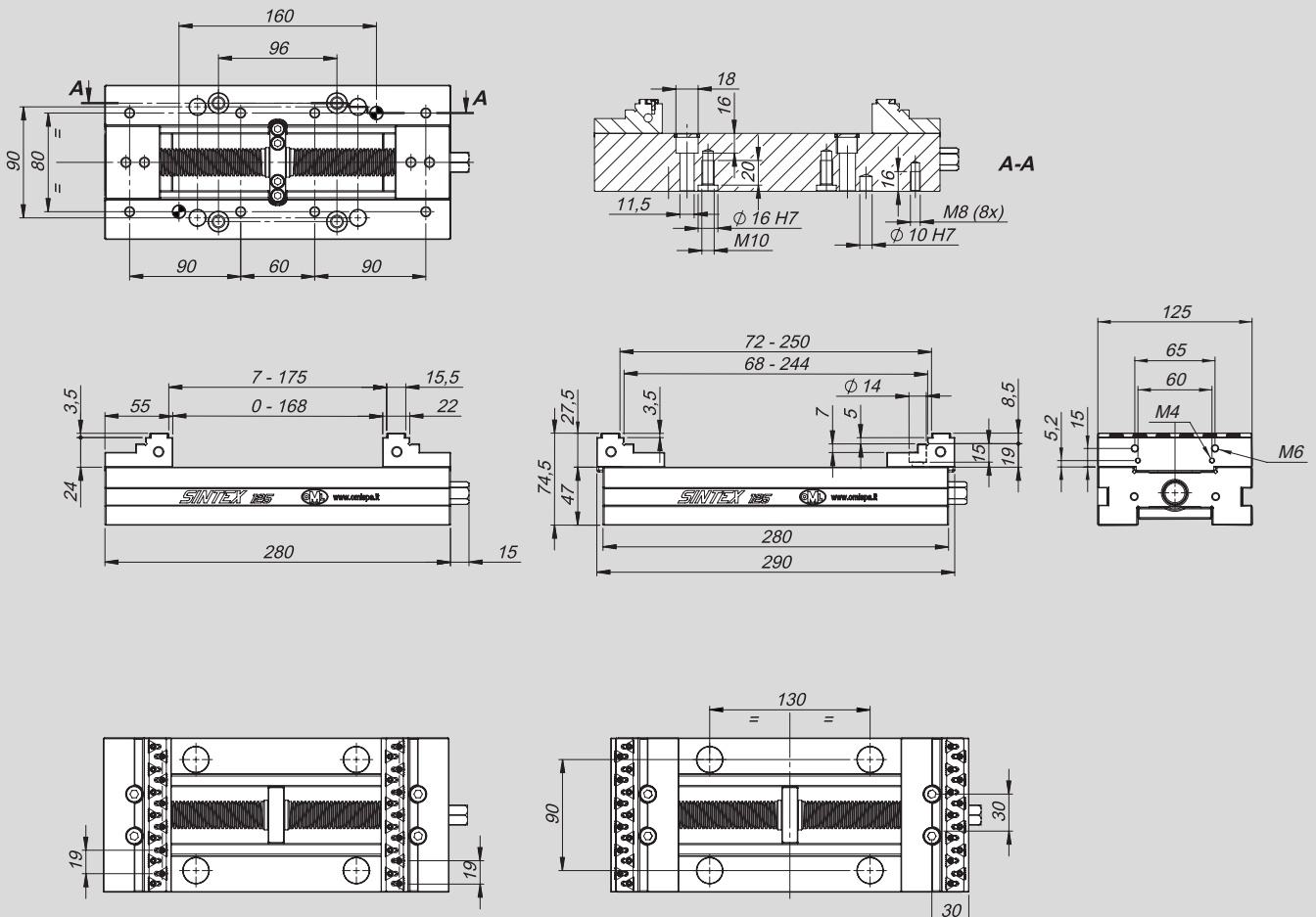

Attrezzatura di bloccaggio **MC** con: chiave poligonale, ganascia guidata (a richiesta ganascia oscillante), piastrina di fermo laterale, coppia chiavette di posizionamento **h6** a scelta, carter protezione vite, 4 staffe di fissaggio, **coppia di ganasce senza rivestimento in carburo di tungsteno, 1 coppia di parallele CLAK (PP), 1 chiave TORX a bandiera e un set 10 viti**, cassa imballo in cartone. Gli inserti SinterGrip **non sono inclusi**: richiedeteli al vostro rivenditore di fiducia.

Clamping equipment **MC** complete with: wrench, rigid slide way (floating slide-way at request for raw workpiece), work stop, pair of positioning keys **h6**, cover for protection of the screw, 4 clamps, **pair of jaws without tungsten carbide coating, 1 pair of parallels (PP), 1 wrench TORX T9 and 1 kit of 10 screws**, cardboard box. SinterGrip inserts **are not included**: ask to your local dealer.



Codice - Code	Prezzo - Price (€)	Offerta - Offer (€)
33 58 06 51	<del>1.511,00</del>	1.150,00
33 58 06 52	<del>1.567,00</del>	1.240,00
33 58 06 53	<del>1.820,00</del>	1.308,00
33 58 07 51	<del>2.439,00</del>	2.093,00
33 58 07 52	<del>2.826,00</del>	2.260,00



Codice - Code	Descrizione - Description	
58450119	Set 10 inserti STD per acciaio Set of 10 inserts STD for steel	
	<del>€ 237,00</del>	€ 205,00
58450129	Set 10 inserti HRC per acciaio temperato - titanio Set of 10 inserts HRC for hardened steel - titanium	
	<del>€ 237,00</del>	€ 205,00
58450139	Set 10 inserti ALU per alluminio Set of 10 inserts ALU for aluminium	
	<del>€ 237,00</del>	€ 205,00

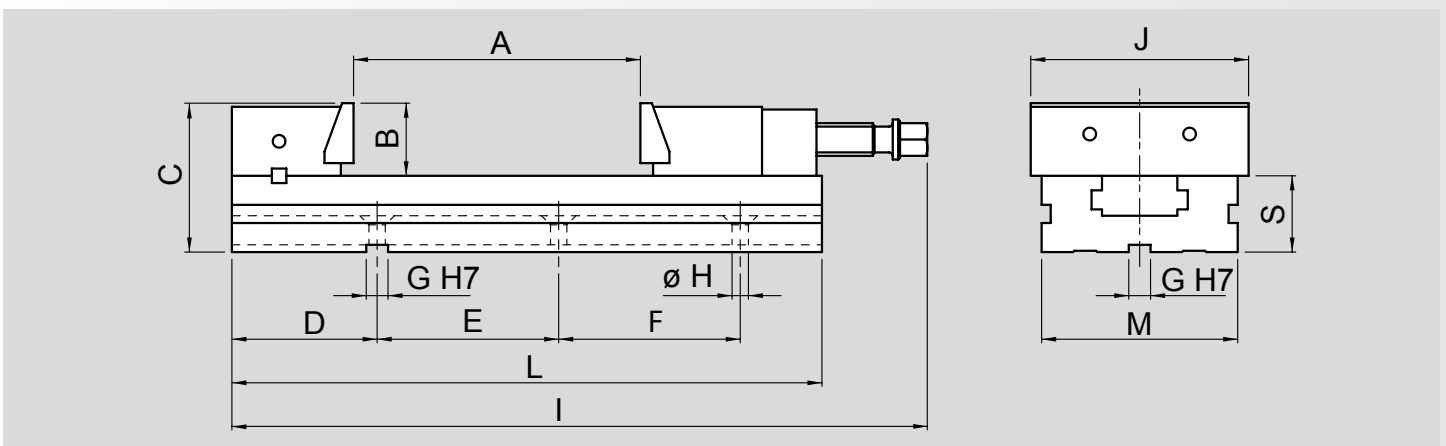

Codice Code	Modello Type	A	B	C	D	E	F	G	H	I	J	L	M	S	Peso Weight
		mm	mm	mm	mm	mm	mm	mm	mm	mm	mm	mm	mm	mm	Kg
33 58 06 51	MC 150 x 200	200	50	102	120	200	-	18	12,5	482	150	415	128	52	25,5
33 58 06 52	MC 150 x 250	250	50	102	120	100	100	18	12,5	532	150	465	128	52	27,5
33 58 06 53	MC 150 x 300	300	50	102	120	100	100	18	12,5	587	150	520	128	52	30,4
33 58 07 51	MC 200 x 300	300	70	136	150	150	150	18	12,5	656	200	570	168	66	66,0
33 58 07 52	MC 200 x 400	400	70	136	150	200	200	18	12,5	756	200	670	168	66	68,0

La nuova MORSA **LC** si affianca alle originali OML TC e MC come soluzione "low cost".

The new **LC** VISE joins the original OML TC and MC VISES as "low cost" solution.



Codice - Code	Prezzo - Price (€)	Offerta - Offer (€)
77 58 95 01	<del>675,00</del>	<b>557,00</b>
77 58 96 01	<del>818,00</del>	<b>679,00</b>
77 58 96 02	<del>998,00</del>	<b>794,00</b>
77 58 97 01	<del>1.628,00</del>	<b>1.351,00</b>
77 58 97 02	<del>1.951,00</del>	<b>1.588,00</b>

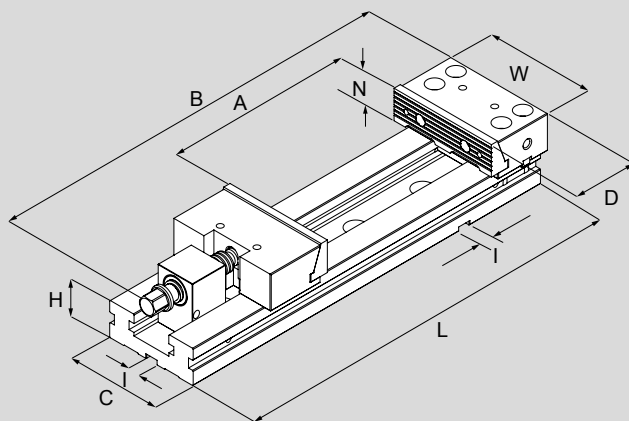

Codice Code	Modello Type	W	N	A	L	B	C	D	H	I	Peso Weight
		mm	mm	mm	mm	mm	mm	mm	mm	mm	Kg
77 58 95 01	LC 125 x 150	125	40	150	345	410	95	77,9	40	16	13
77 58 96 01	LC 150 x 200	150	50	200	420	500	125	89,4	50	16	26
77 58 96 02	LC 150 x 300	150	50	300	520	600	125	89,4	50	16	29
77 58 97 01	LC 200 x 300	200	65	300	595	680	170	113,0	70	16	69
77 58 97 02	LC 200 x 400	200	65	400	695	780	170	113,0	70	16	74

## SinterGrip: THE NEW CHOICE

**SinterGrip** sono inserti in metallo duro sintetizzato tipo ISO P30:P35 e rivestito con metodo PVD.

**SinterGrip** are solid carbide serrated inserts type ISO P30:P35 and coated with method PVD.



Codice - Code	Descrizione - Description	
58450119	Set 10 inserti STD per acciaio Set of 10 inserts STD for steel	
	<del>€ 237,00</del>	€ 205,00
58450129	Set 10 inserti HRC per acciaio temperato - titanio Set of 10 inserts HRC for hardened steel - titanium	
	<del>€ 237,00</del>	€ 205,00
58450139	Set 10 inserti ALU per alluminio Set of 10 inserts ALU for aluminium	
	<del>€ 237,00</del>	€ 205,00

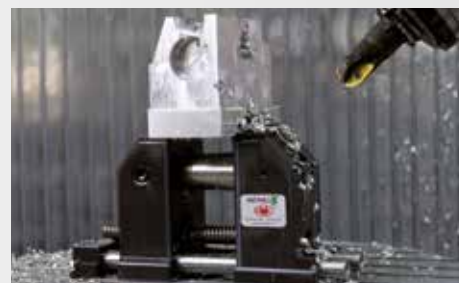
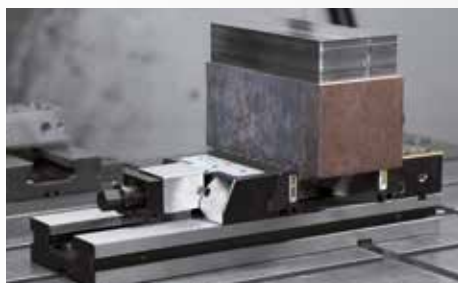

## Set ganasce per SinterGrip Jaws set for SinterGrip

## GANASCE JAWS

Coppia di ganasce senza rivestimento in carburo di tungsteno. Il set comprende una coppia di ganasce, 1 coppia di parallele CLAK (PP), 1 chiave TORX a bandiera e un set 10 viti.

Pair of jaws without tungsten carbide coating. The set includes one pair of jaws, 1 pair of parallels (PP), 1 wrench TORX T9 and 1 kit of 10 screws.



Codice - Code	Prezzo - Price (€)	Offerta - Offer (€)
58 45 12 19	<del>298,00</del>	238,00

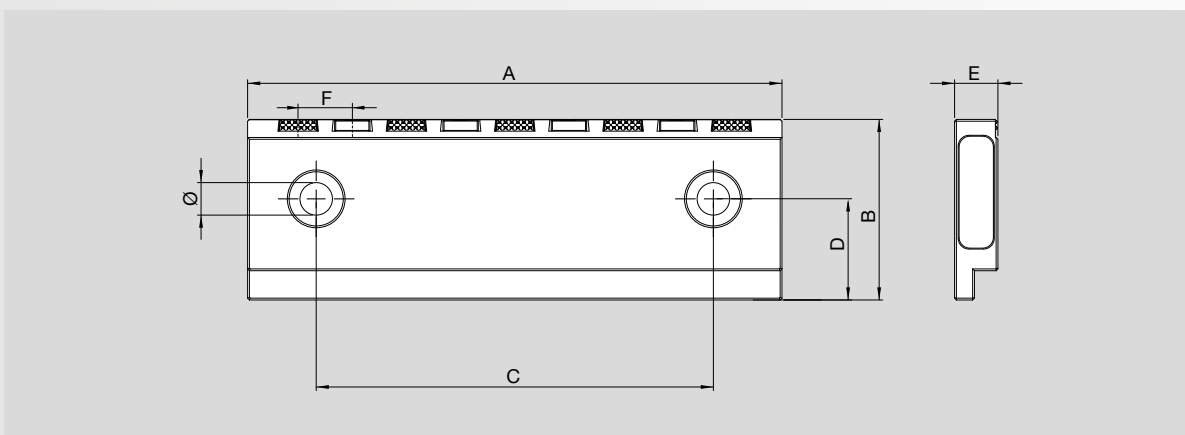

Codice Code	Modello Type	A	B	C	D	D1	E	Ø	H parall.	F	n. inserti n° inserts
58 45 12 19	OML - TC/MC 150 mm	mm 148	mm 50	mm 110	mm 28	mm -	mm 12	mm 9	mm 47	mm 15	9

# CUBI TOMBSTONE

## Cubi sgrossati Tombstone rough milled



I cubi e le spalle in offerta sono in fusione di ghisa GJL 300. Il prezzo include la lavorazione per l'interfaccia al pallet della macchina utensile come da normativa JIS, (macchine utensili giapponesi), e la sgrossatura delle facce con 4 mm di sovrametallo sul totale.

A richiesta la base può essere lavorata secondo specifiche del cliente.

The tombstones and the crankwebs in the offer are in cast iron GJL 300. The price includes the working for the adaptation to the machine tool pallet according to the JIS specifications, (Japanese machine tools), and the faces are rough milled with 4 mm of overall material.

Upon request the base can be machined following customer's specifications.

Codice - Code	Prezzo - Price (€)	Offerta - Offer (€)
57 40 60 36	<del>3.430,00</del>	<b>1.733,00</b>
57 40 60 56	<del>4.730,00</del>	<b>2.310,00</b>
57 40 60 91	<del>6.703,00</del>	<b>3.665,00</b>
57 40 61 21	<del>9.366,00</del>	<b>7.245,00</b>

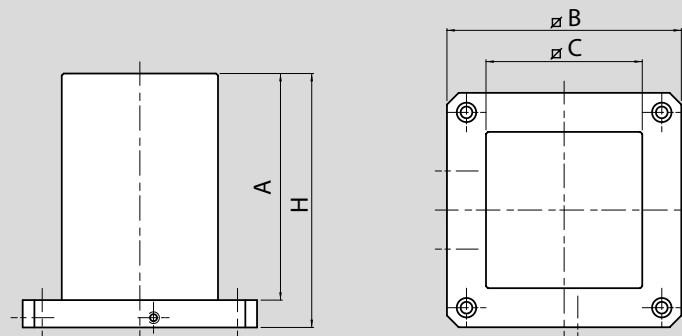

### Ghisa - Cast iron

Codice - Code	A	B	C	H	Peso - Weight
	mm	mm	mm	mm	Kg
57 40 60 36	615	400	254	660	220
57 40 60 56	655	500	354	700	329
57 40 60 91	810	630	454	860	607
57 40 61 21	945	800	554	1000	808



## Spalle sgrossate Crankwebs rough milled

# SPALLE CRANKWEBS

I cubi e le spalle in offerta sono in fusione di ghisa GJL 300. Il prezzo include la lavorazione per l'interfaccia al pallet della macchina utensile come da normativa JIS, (macchine utensili giapponesi), e la sgrossatura delle facce con 4 mm di sovrametallo sul totale.

A richiesta la base può essere lavorata secondo specifiche del cliente.

The tombstones and the crankwebs in the offer are in cast iron GJL 300. The price includes the working for the adaptation to the machine tool pallet according to the JIS specifications, (Japanese machine tools), and the faces are rough milled with 4 mm of overall material.

Upon request the base can be machined following customer's specifications.



Codice - Code	Prezzo - Price (€)	Offerta - Offer (€)
57 40 90 26	<del>3.430,00</del>	1.733,00
57 40 90 46	<del>4.730,00</del>	2.310,00
57 40 90 66	<del>6.703,00</del>	3.665,00
57 40 90 91	<del>9.366,00</del>	7.245,00

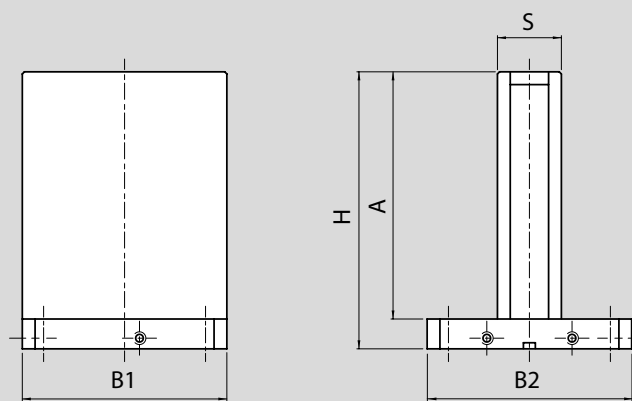

### Ghisa - Cast iron

Codice - Code	A	B	H	S	Peso - Weight
	mm	mm	mm	mm	Kg
57 40 90 26	615	400	660	154	209
57 40 90 46	655	500	700	154	265
57 40 90 66	810	630	860	204	485
57 40 90 91	945	800	1000	304	810

# TETRABLOK

## Attrezzatura di bloccaggio a 4 posizioni 4 positions clamping equipment

L'attrezzatura di bloccaggio a 4 posizioni **TETRABLOK** si affianca a CIVI 2000 con un ottimo rapporto qualità/prezzo. Attrezzatura di bloccaggio a 4 posizioni costituita da n. 1 base di lunghezza a scelta, n. 1 supporto fisso, n. 4 elementi di bloccaggio, n. 4 fermi laterali, n. 1 coppia chiavette posizionamento, n. 1 chiave a T.

The 4 workpieces clamping equipment **TETRABLOK** joins CIVI 2000 with a good price/quality ratio.

Tetrablok 4 workpieces clamping equipment complete with n. 1 base (length optional); n. 1 fixed support; n. 4 clamping units; n. 4 workstops; n. 1 pair of positioning keys; n. 1 T-wrench.



Codice - Code	Prezzo - Price (€)	Offerta - Offer (€)
77 58 81 01	<del>1.643,00</del>	<b>951,00</b>
77 58 81 02	<del>1.867,00</del>	<b>1.070,00</b>
77 58 81 03	<del>2.019,00</del>	<b>1.178,00</b>
77 58 82 01	<del>2.093,00</del>	<b>1.190,00</b>
77 58 82 02	<del>2.247,00</del>	<b>1.303,00</b>
77 58 82 03	<del>2.411,00</del>	<b>1.416,00</b>

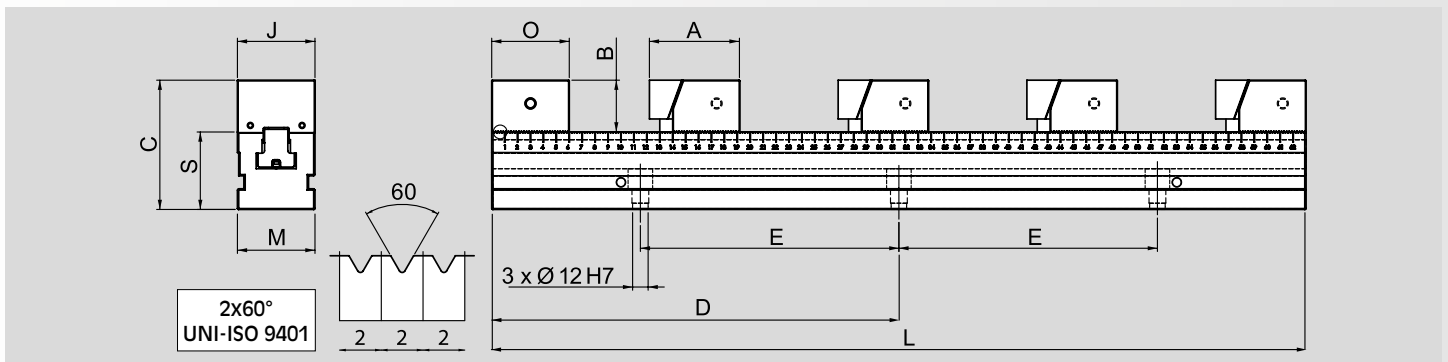

Codice Code	Modello Type	A	B	C	D	E	J	L	M	O	S ± 0,01	Peso Weight
77 58 81 01	Tetrablok 60	mm	mm	mm	mm	mm	mm	mm	mm	mm	mm	Kg
77 58 81 02		70	40	100	200	100	60	400	60	60	60	16,9
77 58 81 03		70	40	100	250	150	60	500	60	60	60	19,9
77 58 82 01	Tetrablok 90	mm	mm	mm	mm	mm	mm	mm	mm	mm	mm	Kg
77 58 82 02		80	45	115	200	100	90	400	90	70	70	27,6
77 58 82 03		80	45	115	250	150	90	500	90	70	70	32,8
77 58 82 03		80	45	115	315	200	90	630	90	70	70	36,7

### Capacità di serraggio - Clamping capacity

Modello - Type	A max			
	mm	mm	mm	Kg
TETRABLOK / 60-400	270	100	43	15
TETRABLOK / 60-500	370	150	76	40
TETRABLOK / 60-630	500	215	120	73
TETRABLOK / 90-400	249	84	29	-
TETRABLOK / 90-500	349	134	62	26
TETRABLOK / 90-630	479	199	106	59

**Cubo croce con Tetrablok**  
**Cross tombstone with Tetrablok**

**CUBI**  
**TOMBSTONE**

Cubo a croce in acciaio  
 con 4 TETRABLOK 60/90-630 mm

Steel cross tombstone  
 with 4 TETRABLOK 60/90-630 mm



Codice - Code	Prezzo - Price (€)	Offerta - Offer (€)
33 58 81 01	<del>11.199,00</del>	7.073,00
33 58 81 02	<del>11.397,00</del>	7.462,00
33 58 82 01	<del>13.035,00</del>	8.040,00
33 58 82 02	<del>13.298,00</del>	8.429,00

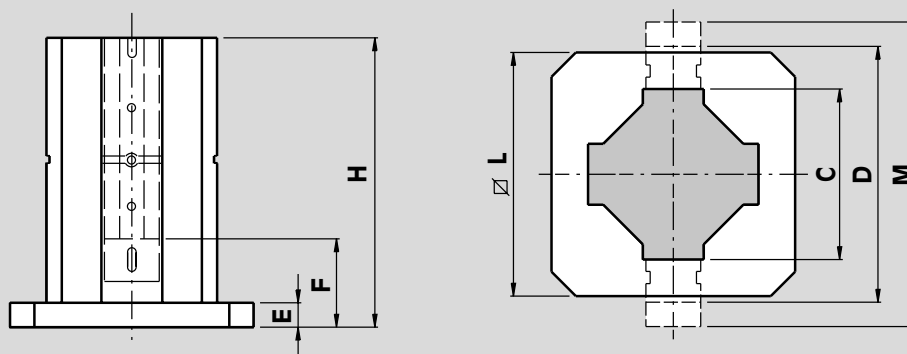

**Acciaio - Steel**

Codice - Code	Modello - Type	C	D	E	F	H	L	M	Peso - Weight
		mm	mm	mm					Kg
33 58 81 01	TETRABLOK 60/630	250	370	40	120	690	400	450	230
33 58 81 02	TETRABLOK 60/630	300	420	40	120	690	500	500	275
33 58 82 01	TETRABLOK 90/630	250	390	40	130	690	400	480	289
33 58 82 02	TETRABLOK 90/630	300	440	40	130	690	500	530	334



Tavole a indexaggio meccanico non motorizzate ad attuazione programmabile indiretta

Automatic mechanical indexing tables

Codice - Code	Prezzo - Price (€)	Offerta - Offer (€)
51 99 13 01	<del>4.628,00</del>	<b>3.931,00</b>



Tavole a indexaggio meccanico non motorizzate ad attuazione programmabile indiretta

Automatic mechanical indexing tables

Codice - Code	Prezzo - Price (€)	Offerta - Offer (€)
51 99 13 02	<del>5.786,00</del>	<b>4.915,00</b>

**RIGIDITÀ**

L'esclusivo sistema "Touchdex" consente l'applicazione di una forza di bloccaggio da 2 a 3 volte superiore rispetto al sistema in uso sulle tavole CNC.



**RIGIDITY**

The exclusive "Touchdex" system provides a clamping force 2 to 3 times that an ordinary index table thus allowing heavy machining.

**PRECISIONE**

Posizionamento angolare 30 sec.  
Ripetibilità del posizionamento ± 3 sec.

**PRECISION**

Indexing accuracy of less then 30 sec.  
Repeat accuracy ± 3 sec.

**ECONOMICITÀ**

**MINIMUM INVESTMENT**

**ESTREMA VERSATILITÀ**

L'assenza di collegamenti elettrici, pneumatici o idraulici ne permette l'utilizzo anche su centri di lavoro multipallet sia orizzontale sia verticali.

**VERSATILITY**

Since it has no electric or pneumatic connections, it can be installed on multi-pallet machining centers either vertical or horizontal with the possibility to create flexible production system.

**FUNZIONAMENTO**

Non appena la barra di spinta viene premuta, il perno di bloccaggio si ritrae grazie al suo meccanismo zigrinato a cam.

Premendo ulteriormente la barra di spinta, la tavola inizia a ruotare.

Sino a che la barra di spinta non ha concluso la sua corsa di ritorno, la tavola e il perno di bloccaggio rimangono in posizione.

Conclusa la sua corsa di ritorno, il perno di bloccaggio si innesta con la ghiera di posizionamento e fissa la tavola.

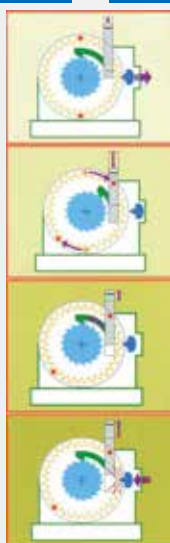

**WORKING**

When the pushbar is pressed down a little, the lock pin retracts due to a grooved cam mechanism.

When pressed down further, the faceplate begins to rotate

The pushbar returns, but until a certain position is reached the faceplate and the lock pin continue to be as they were.

When the pushbar reaches the highest position, the lock pin engages with the positioning gear and fixes the table.

**PROGRAMMAZIONE**

L'angolo di indexaggio voluto si ottiene con una differente corsa dell'asse Z della MU in funzione della lunghezza della barra di spinta.

**PROGRAM**

By means of different strokes of the Z-axis it is possible to reach needed indexing angle.

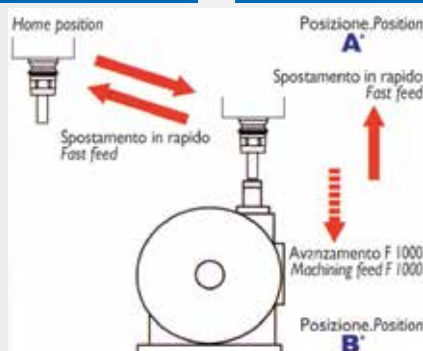

Codice - Code	Modello - Type	Incrementi angolari - Indexing angles		Corsa barra - Pushbar stroke	A
		min.	max	mm	mm
51 99 13 01	FDM - 150	5°	45°	38	127
51 99 13 02	FDM - 200-04	5°	90°	78	208



**IMAGINATION HAS NO LIMIT**

**Ganasce SinterGrip:**

ganasce reversibili per la minima profondità di bloccaggio e senza pre-lavorazione

**SinterGrip jaws:**

Reversible jaws for minimum clamping depth and without pre-machining



**Ganasce SinterGrip**  
**SinterGrip jaws**



**Gamma di serraggio molto ampia**

Massima flessibilità  
 Per bloccaggio esterno ed interno

**Wide clamping range**

Maximum flexibility  
 For external and internal clamping



**Bloccaggio meccanico**

Totalmente protetta con sistema telescopico brevettato. La grande trasmissione di forza consente elevate prestazioni nel processo di lavorazione

**Mechanical clamping**

Totally protected with patented telescopic system. The large power transmission allows high performance in the manufacturing process



**Interfaccia**

per sistemi di bloccaggio zero point e fori di montaggio come standard

**Interface**

For Zero Point clamping systems and mounting holes as standard

- **Totamente protetta**  
con sistema telescopico  
brevettato

- **Totally protected**  
With patented telescopic  
system



- **Fori passanti**  
per bloccaggio  
frontale

- **Through holes**  
For frontal clamping

- **Ideale**  
per automazione e  
sistemi di palletizzazione

- **Ideal**  
For automation and  
palletizing systems

- **Montaggio flessibile**  
su tavola macchina  
tramite staffe (opzionale)

- **Flexible mounting**  
on machine tool pallet using  
clamps (optional)

**Ganascia doppio bloccaggio**  
**Double clamping jaw**  
(for double clamping)



**Piastra di fermo**  
**Retainer plate**  
(for fixed clamping)



- **Aperture di uscita trucioli molto ampie**  
per garantire un flusso di trucioli ottimizzato
- **Very large drainage slots**  
for coolant and chips

- **Guide trattate e rettificate di precisione**  
per la massima precisione e ripetibilità

- **Treated and precision ground guides**  
for maximum accuracy and repeatability

- **Parallele**  
a ricambio rapido Clak System

- **Parallels**  
with quick change Clak System

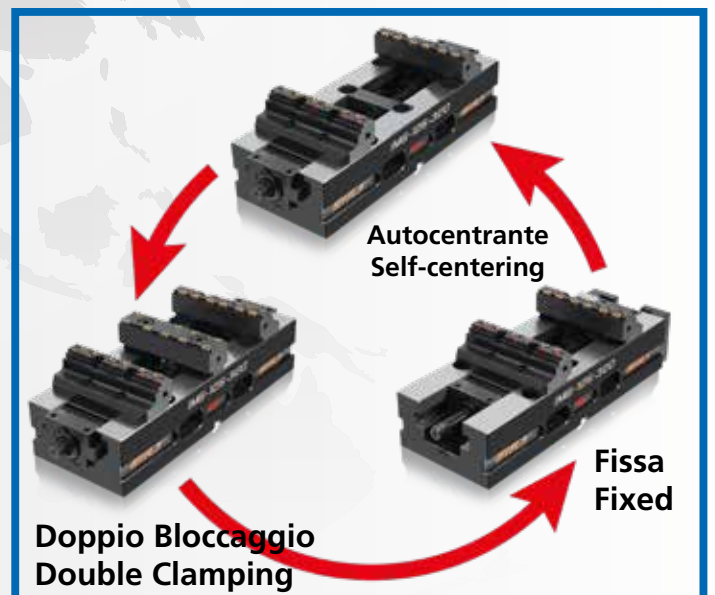



APS è il sistema d'interfaccia universale tra la macchina utensile, l'attrezzatura di bloccaggio e/o direttamente il pezzo da lavorare.

La flessibilità del sistema APS consente il posizionamento ed il bloccaggio in un'unica operazione con ripetibilità < 0,005 mm.

APS is a universal connection between the machine tool, the clamping device and/or the workpiece.

Positioning and clamping in one operation with repeatability accuracy < 0,005 mm (0.0002").

**I vostri tempi di attrezzaggio si ridurranno del 90%.  
Your set-up times will be reduced by 90 %.**



### **SISTEMA DI BLOCCAGGIO A 3 GRIFFE a 120°**

APS 140 Premium è l'UNICO sistema di bloccaggio ZERO POINT a 3 griffe a 120°.

### **CLAMPING SYSTEM WITH 3 JAWS AT 120°**

APS is the only one clamping system ZERO POINT with 3 jaws at 120°.



### **INNOVATIVO TRATTAMENTO ANTIATTRITO E ANTICORROSIONE**

Per mantenere la durezza 62 HRC agli elementi principali del bloccaggio (non realizzabile con l'acciaio INOX) abbiamo applicato un innovativo sistema antiattrito e anticorrosione ai perni e alle griffe.

### **INNOVATIVE ANTIFRICTION AND ANTICORROSION TREATMENT**

To maintain the hardness 62 HRC to the main lock elements (not possible with stainless steel), we applied an innovative anti-friction and anti-corrosion system to the pins and jaws.

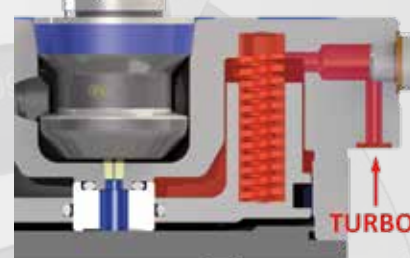

### **FUNZIONE TURBO INTEGRATA**

Turbo è la funzione per mezzo della quale l'aria compressa incrementa la forza di bloccaggio "PULL DOWN" esercitata dalle molle fino a 30.000 N.

### **TURBO FUNCTION INTEGRATED**

Turbo is the function by means of which the compressed air increases the clamping force applied by the springs until reaching the "PULL DOWN" clamping force of 30,000 N.



**Esempi di impiego - Working examples**



# APS Combi

Sistema di bloccaggio Zero Point  
Zero Point Clamping System

Automatic Positioning System



Esempi di impiego - Working examples

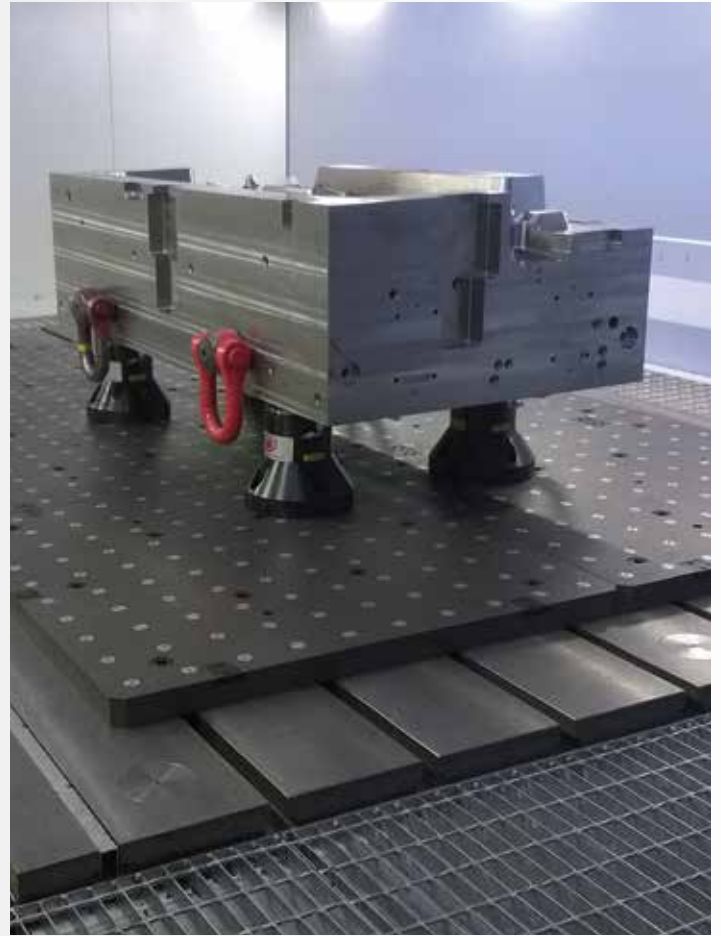



MODULAR CLAMPING SYSTEMS



SINTERGRIP



APS



FMS



TC



MC



LC



CLAK SYSTEM



GENIUS



CIVI 2000



CAM SYSTEM



HOLDING CLAMPS



VARI CLAMP



DUO - LOCK

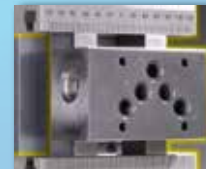

JAWS



SC



ST5-2G



FAST CLAMPS



TWIN VISE



IMG



**OFFICINA MECCANICA LOMBARDA S.r.l.**

Via Cristoforo Colombo, 5 - 27020 Travacò Siccomario (PV) - ITALY

Tel. +39 0382 55 96 13 - Fax +39 0382 55 99 42 - email: [omlspa@omlspa.it](mailto:omlspa@omlspa.it) - [www.omlspa.it](http://www.omlspa.it)

CODE 10 70 58 47 - printed April 2020

Offerte Speciali fino ad esaurimento scorte • Special Offers until end of the stock